

# SIGNAL PROCESSING GUIDE

**transcell**<sup>®</sup>

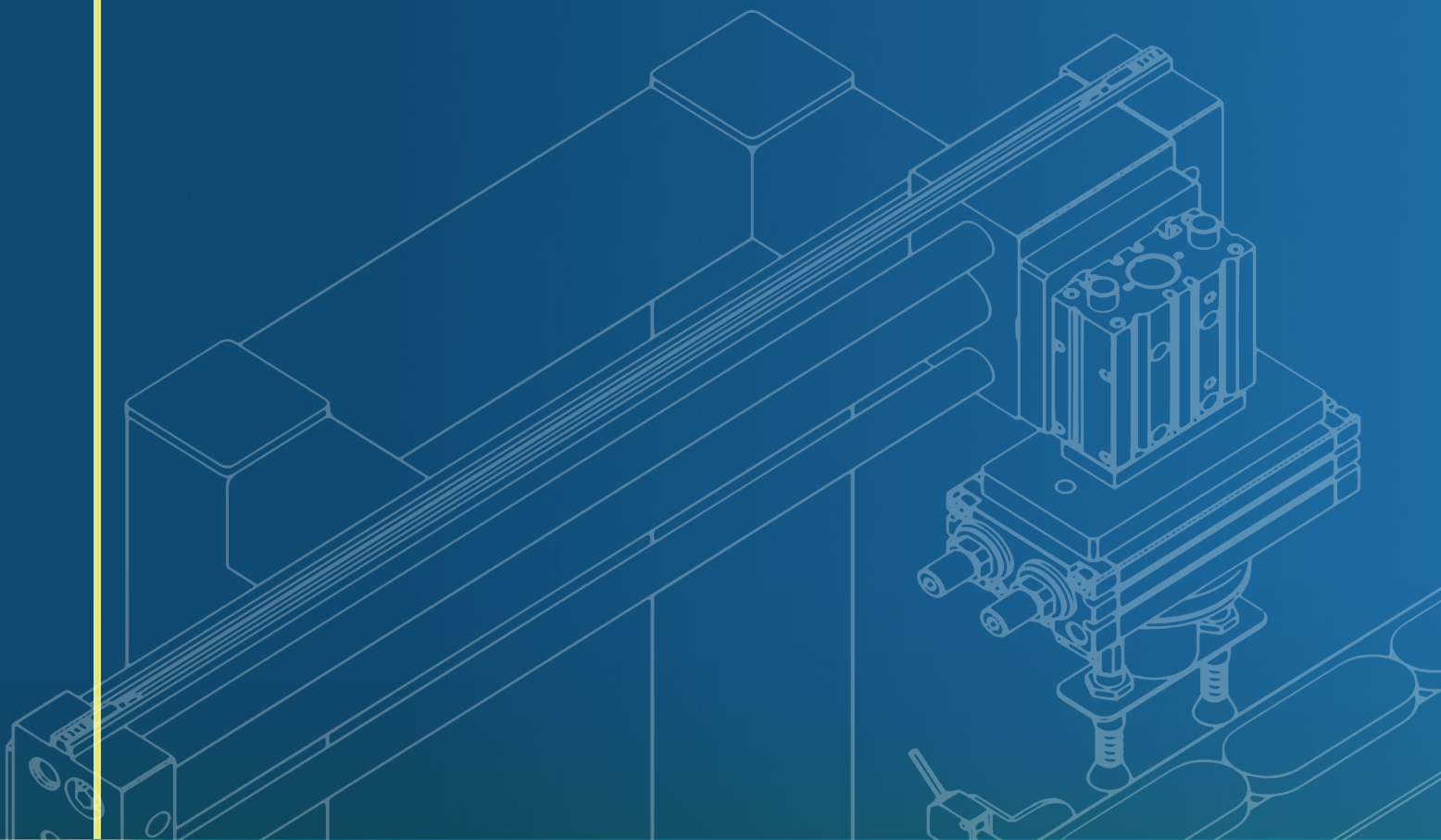

# We get you, from Input to Output

Transcell® signal processing solutions integrate with your systems, ensuring your load cells and torque transducers deliver the information you need.

## Indicator

Converts signal from a load cell or torque transducer into a digital value that is displayed on-screen, can feature digital or analog outputs or relay controls

## External or Internal Signal Conditioners

Converts the native low-level signal from a load cell or torque transducer into a more usable high-level analog signal or a digital signal; the conditioned signal can then be fed into a datalogger, motion controller, or PLC.

## Junction or Summing Box

Combines multiple load cell signals into a single analog signal or multi-channel digital signal.

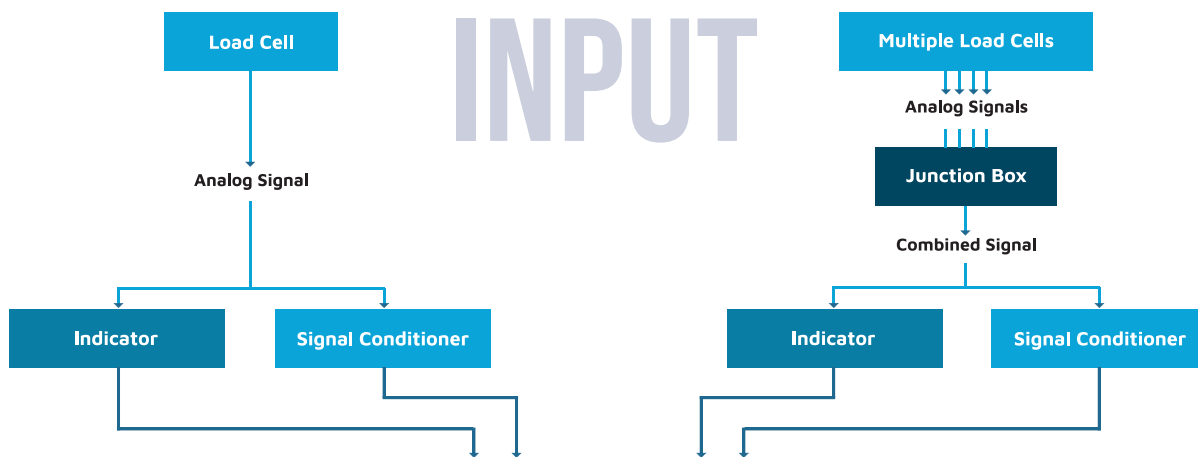

## Digital Output Options

## Analog Output Options

4-20mA, 12±8mA, 0-24mA,  
0-5V, ±5V, 0-10V, ±10V



### RS-232

A 9-pin digital serial connection to a computer, PCL or simple data logger



### Isolated RS-232

Eliminates signal noise and protects computers from voltage from improper grounding and and common-mode transient events



### RS-485

A Modbus protocol interface that serves multiple devices attached to the same bus with output to USB, GSM or Ethernet ports.



### USB

Universal serial connection that communicates with a computer or printer.



### Ethernet IP

Transmits digital data via EtherNet/IP (EIP)



### Modbus TCP/IP

A serial communications protocol for use with programmable logic controllers (PLCs).



### Profibus DP

The protocol communicates between field load cells and control systems or controllers. The platform is based on RS485 and the EN-5017 European standard and handles wired, wireless, and fiber optic transmission.



### PROFINET

The versatile and secure Ethernet interface handles precise, ultra-fast industrial communication for industrial applications. It supports communication through IO-controllers and IO-receivers.



### CAN bus

Controller Area Network (CAN bus) devices can be "daisy chained", eliminating the need for multiple signal wires. Uses include : Vehicles, elevators, manufacturing equipment, and household appliances, etc.

# Wireless Systems

Transcell® indicators and signal processing equipment can incorporate wireless technology into indicators and signal processing equipment.



## Bluetooth Wireless Transmitter

The Bluetooth device connects directly to load cell output wiring. Our digital indicators can incorporate Bluetooth to receive signals from compatible load cells. When connected with Bluetooth 2.0 or 4.0 devices, our load cells and indicators can transmit a signal to a nearby smartphone or computer.



## RF Transmitter

The UHF business band radio device connects directly to the load cell, transmitting to a dedicated receiver.



## Wi-Fi

The standard protocol bridges the load cell with a PC via WiFi/virtual Ethernet port, PC/PLC via RS485/RS232, point-to-point browser connections on computers, tablets, and smartphones, multiple load cells, and W series instruments.

## Applications

- Cranes
- Hoists
- Industrial mobile applications
- Storage towers or hoppers

### Transcell Technology, Inc.

975 Deerfield Parkway  
Buffalo Grove, IL 60089 USA  
Ph: +1 (847) 419-9180  
Fax: +1 (847) 419-1515

[www.transcell.com](http://www.transcell.com)

transcell®