

FDI-02 & FDI-02-SS

Force Measurement Indicators

FDI-02



FDI-02-SS



Features

- Peak and Valley Capture Modes
- Independent Calibration Curves for both Tension and Compression Loading Modes
- Up to 7 Calibration Points per Loading Mode (Live Capture or Key-In Entry)
- “Quick Cal” Mode for Live Calibration on Hydraulic / Electromechanical Systems
- Configurable Auto-Zero
- Configurable Averaging Filter
- Full Duplex RS-232C Serial Port
- Stainless Steel Mounting Bracket

Measurement Parameters

Nonlinearity	±0.02% of Full Scale
Display Digits	6 Digits: Selectable 9.99999 to 999,999
Smallest Digital Selection	1, 2, 5
Display Stability	±1/100,000 FS @ 20Hz
Sampling Rate	2 to 1200 Hz
Internal Resolution	>1,000,000 raw counts per mV/V
Load Cell Sensitivity Range	±5 mV/V
Excitation	3.3 V
Units of Measure	ozf, gf, lbf, kgf, N, klbf, kN

Differences	FDI-02	FDI-02-SS
IP Rating	IP64	NEMA 4x / IP65
Housing Material	Aluminum / ABS	Stainless Steel
Battery Power	(4) AA (not included)	Embedded 100hr Rechargeable Battery
AC Power	AC Adapter Included	Battery charger Included

Dimensions

FDI-02

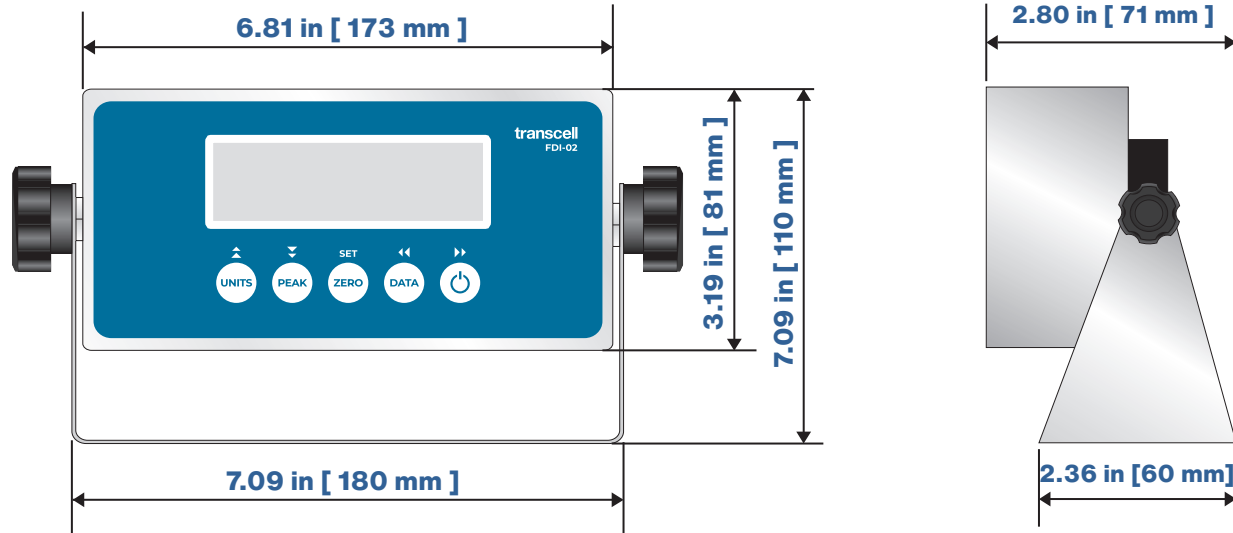

FDI-02-SS

